

1004-42/1004-40/1004-40T/1004-40TW, stressed block

Left side view

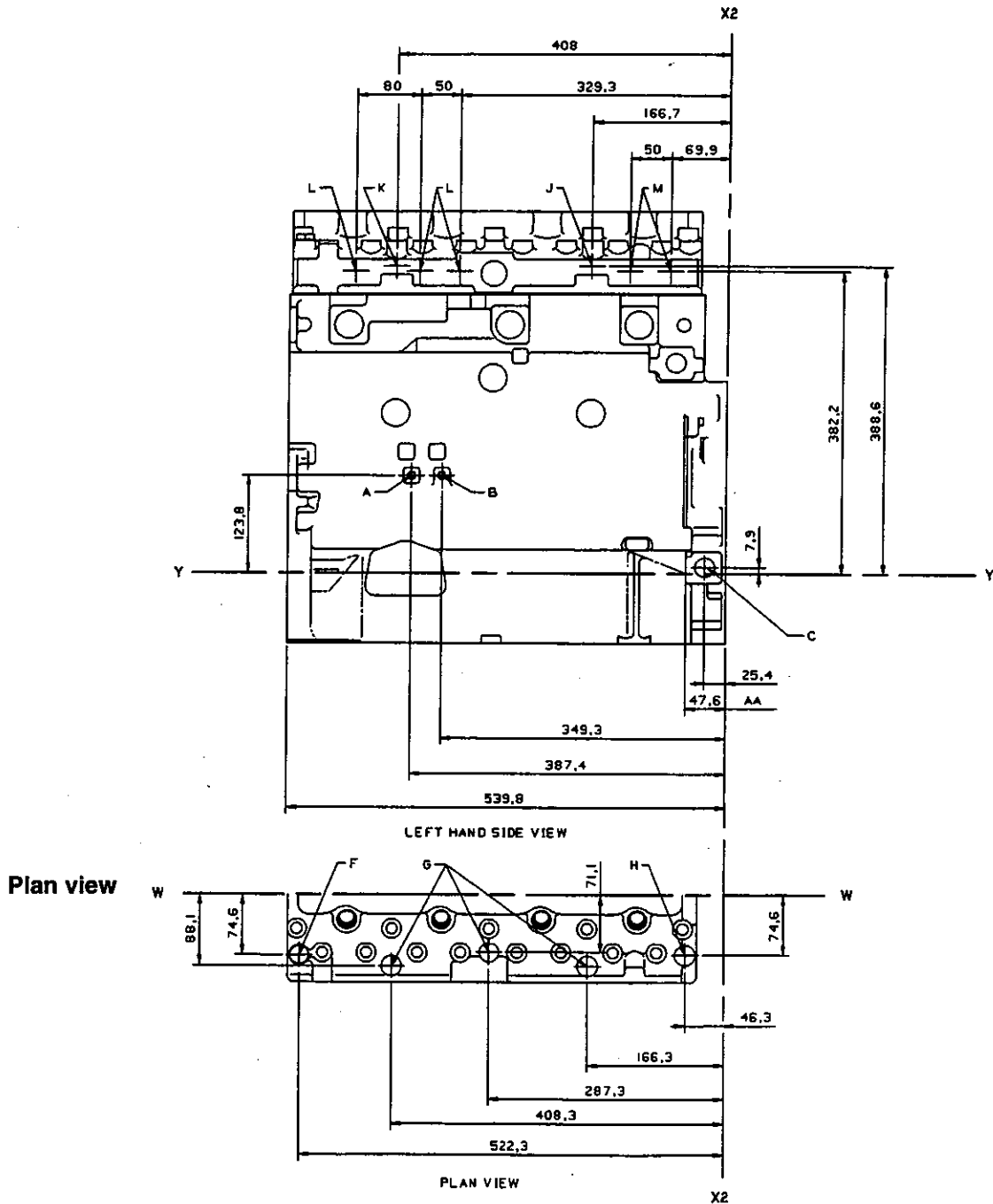

100 mm bore - 3711H061 Cylinder block; 3712H144 Cylinder head  
 103 mm bore - 3711H082 Cylinder block; 3712H152 Cylinder head

# 8D Cylinder head and block tappings

1004-42/1004-40/1004-40T/1004-40TW, stressed block

Front view

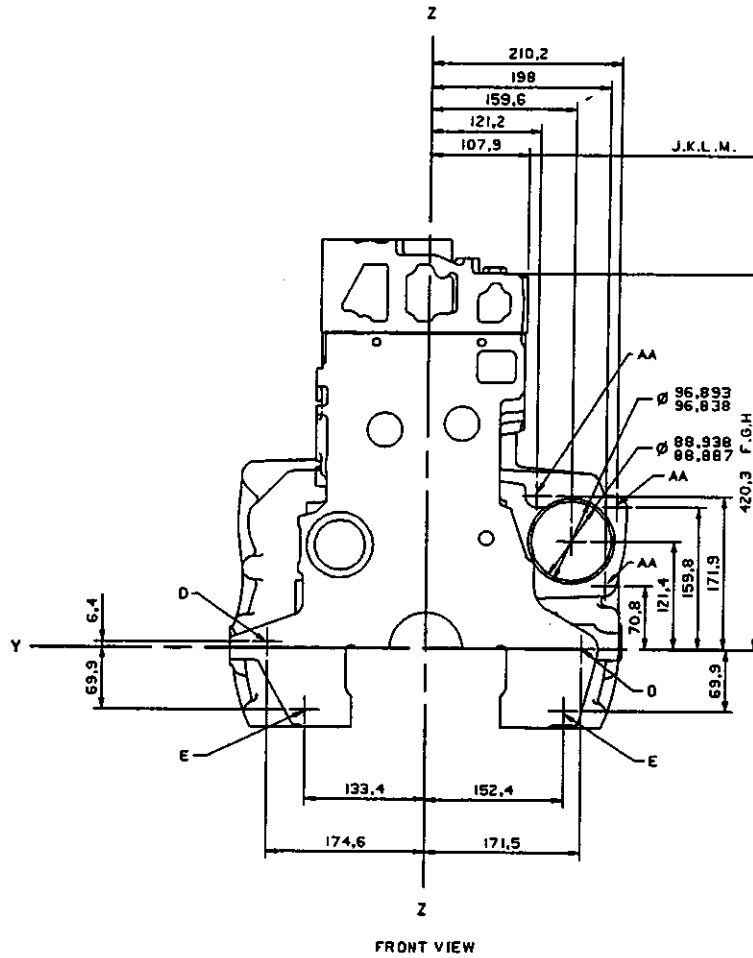

DETAILS OF RELEVANT HOLES ON THIS SHEET

REF	QTY	SIZE	REMARKS
A	1	M10 X 1,5	OIL FEED (PLUGGED)
B	1	1/8-27 NPSI X 8	LUB OIL PRESS (PLUGGED)
C	1	3/4-14 NPSI	TACHOMETER SENSOR (PLUGGED)
D	2	Ø17	ENGINE MOUNTING
E	2	M16 X 2,0 X 32	ENGINE MOUNTING
F	1	5/8-18 UNF X 10,5	THERM. TAPPING (PLUGGED)
G	3	M10 X 1,5 X 20	
H	1	M10 X 1,5 X 20	N/A ONLY
J	1	M6 X 1,0 X 12	N/A ONLY
K	1	M6 X 1,0 X 12	
L	3	M10 X 1,5 X 20	
M	2	M10 X 1,5 X 20	N/A ONLY
AA	3	M10 X 1,5	STARTER MOTOR MOUNTING

NOTE. SOME TAPPINGS ALREADY USED BY OPTION COMPONENTS FITTED

1004-42/1004-40/1004-40T/1004-40TW, stressed block

Right side view

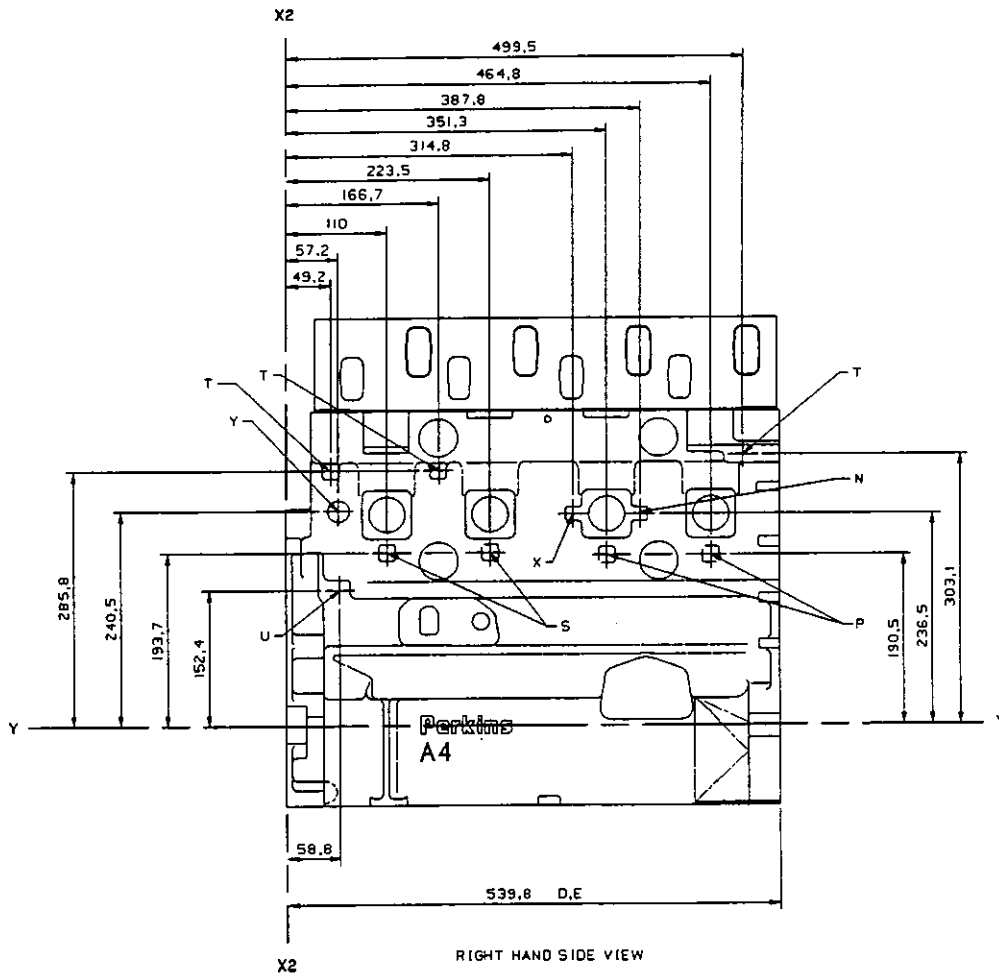

# 8D Cylinder head and block tappings

1004-42/1004-40/1004-40T/1004-40TW, stressed block

Rear view

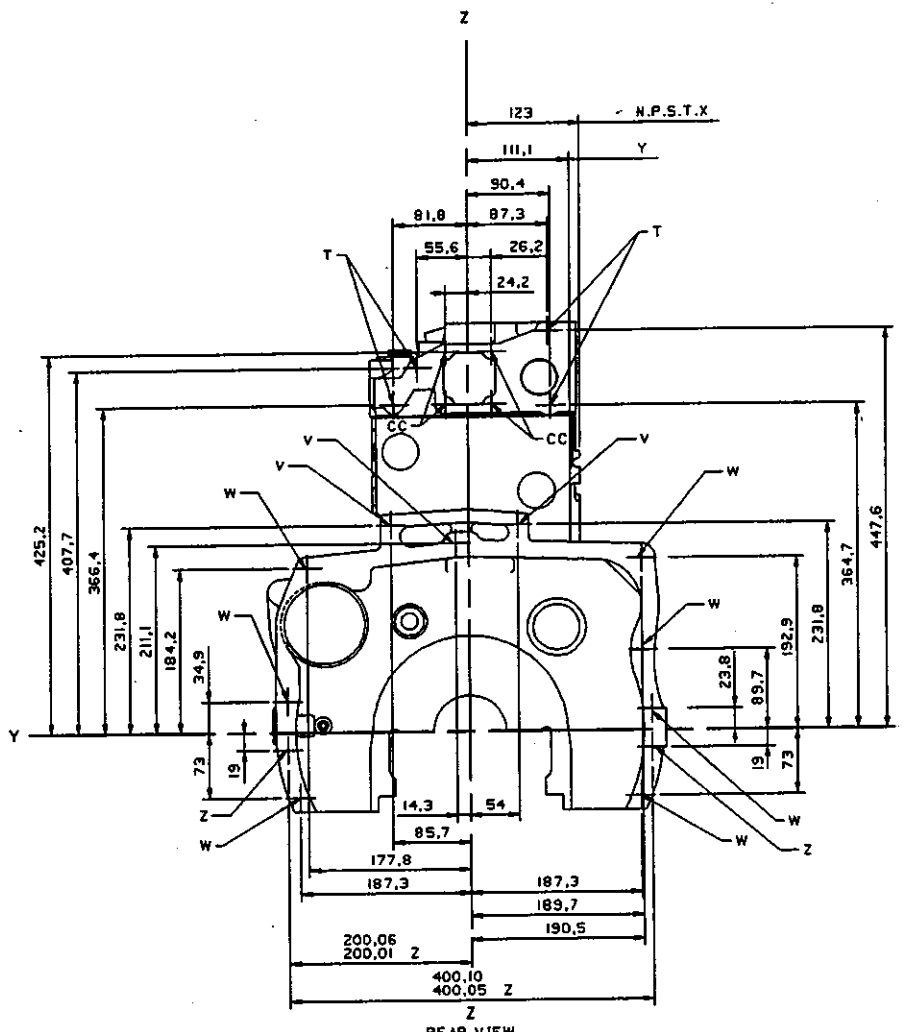

REAR VIEW

DETAILS OF RELEVANT HOLES ON THIS SHEET

REF	QTY	SIZE	REMARKS
N	1	M8 X 1,25 X 16	N.A. ONLY
P	2	M10 X 1,5 X 15	N.A. ONLY
S	2	M10 X 1,5 X 15	
T	7	M10 X 1,5 X 20	
U	1	1/4-18NPSI. X 12	WATER DRAIN IPLUG STAND OUT 7MMI
V	3	M12 X 1,75 X 25,4	
W	7	Ø13	ENGINE MOUNTING
X	1	M8 X 1,25 X 16	
Y	1	3/4-14NPSI.	PLUGGED - WATER HEATER
Z	2	Ø9,55/9,53 X 12,7	DOWEL LOCATION HOLES
CC	4	M8 X 1,25 X 16	

NOTE. SOME TAPPINGS ALREADY USED BY OPTION COMPONENTS FITTED